

H HYDRO
 12 whirlpool jets
 12 vodních trysek

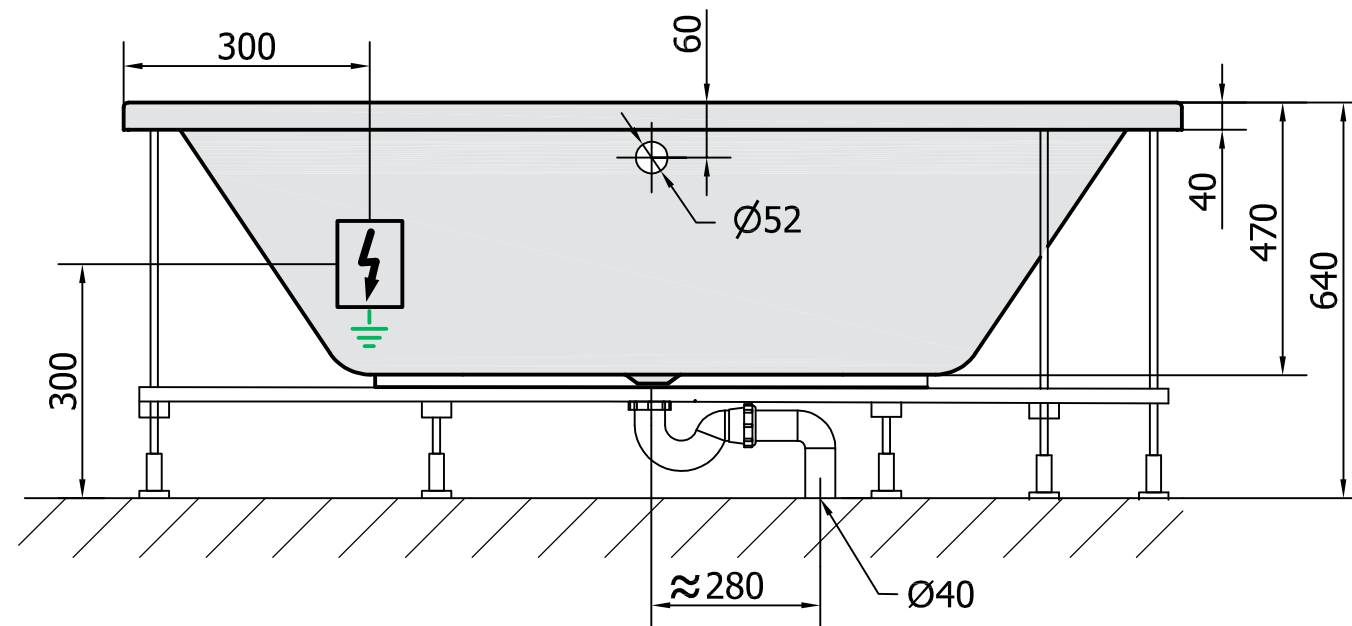

L Electric cable 3x2,5mm²
 Length 2m from the wall
 Elektrický kabel 3x2,5mm²
 Délka kabelu ze zdi 2m

Electrical Characteristic:
 Tension: 220-230V/50hz
 Max. power consumption: 800W
 Electric protection: residual-current device 30mA

Elektrické vlastnosti:
 Napětí: 220-230V/50hz
 Max. spotřeba: 800W
 Elektrické jištění: proudový chránič 30mA

VOLUME 235L

Kreslil vs	Kontroloval	Schválil	Datum	Datum	
			70119H WHIRLPOOL BATH TUB		
VIVA175x80L				List	1 / 1